



SERVICE INFORMATION

SI No. 854-2383	Date November 2002	9-3
PI No.	Distr. all	

Difficult to operate temperature and air distribution control knobs

This SI replaces SI 854-2205 issued in August 2000 and included in 2000 SI Supplement. (approx. 20 cars)

Cars affected

For cars with MCC only

For cars with MCC only 9-3 M98-M00 up to and incl. VIN Y2016481 and Y7005479.

Background

The heat and air distribution control knobs can be difficult to move. The reason for this is twofold: grease missing from certain locations in the heating and ventilation unit and the drum which is pressed against the unit.

Perform the following procedures after customer complaint.

Important

The method described here differs from the corresponding method in WIS.

Symptom description

Difficult to operate temperature and air distribution control knobs. Difficult to control air flow and adjust temperature.

Parts required

87 81 718 (CA: 30576981) Silicone grease (enough for approx. 2 cars)

79 76 897 (CA: 30509261) Screw, 2 per car

If necessary:

51 74 669 (CA: 30585921) Cable

53 35 906 (CA: 30591714) Shaft kit, air distribution

53 30 923 (CA: 30587279) Shaft kit, temperature control knob

53 31 665 (CA: 30586362) Control knob

43 64 279 (CA: 30550626) Telescoping control shaft between control panel and heating and ventilation unit

92 88 127 (CA: 30522088) Butyl tape (enough for

Procedure

- 1 Remove the glove box.
- 2 Remove the center console side panel.
- 3 If necessary, remove the knee shield stay.

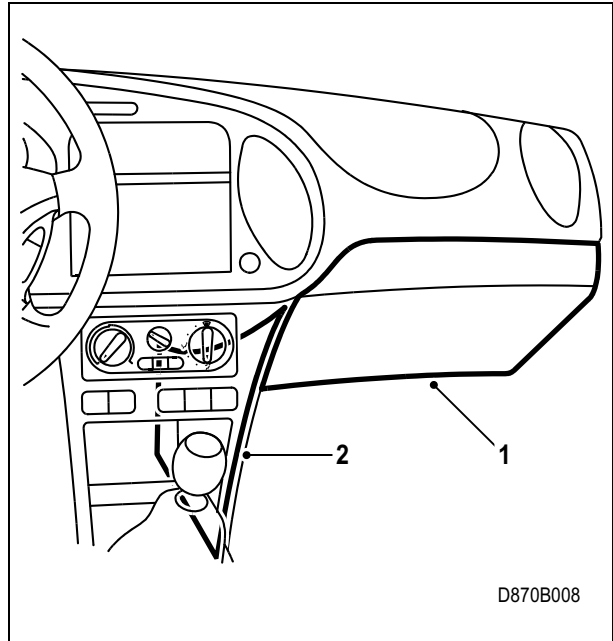

- 4 Remove the air ducts.

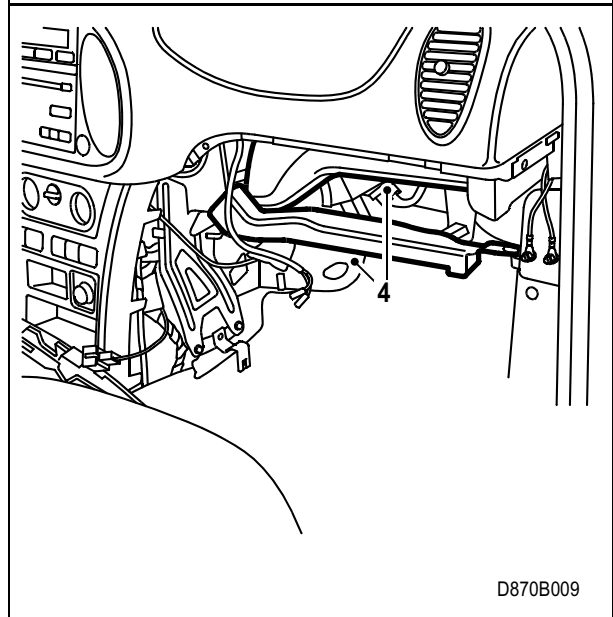

- 5 Remove the data link connector and the lower dashboard section on the driver's side.
- 6 Remove the knee shield on the driver's side.

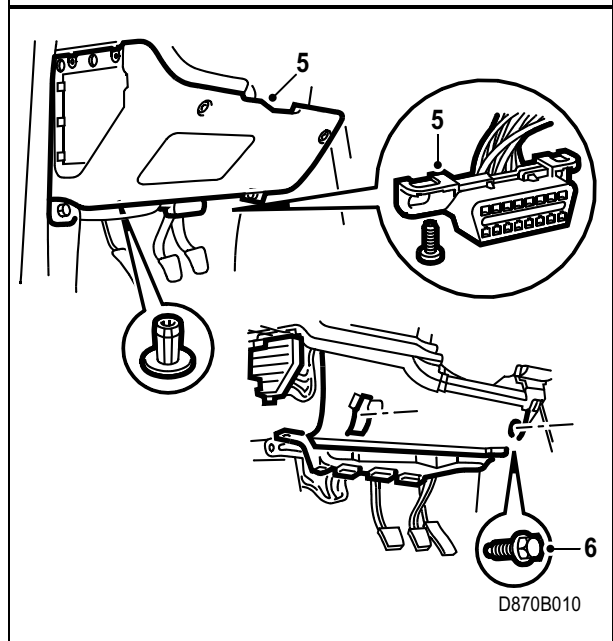

7 Loosen the screws and move the fuse board aside.

8 Remove the air ducts.

9 Check the following:

a that the temperature control knob is not damaged or difficult to move and that the temperature control cable is not difficult to move. Replace the temperature control knob if necessary, see the following method description for "Replacing temperature control knob and shaft". Check the temperature control cable by disconnecting the cable from the lever and turning the temperature controls. If the knob is difficult to manoeuvre, replace if necessary, see WIS - 9-3 - Body - MCC - Adjustment/Replacement - Control cable. Fit the cable to the lever.

b that the air distribution control knob functions satisfactorily. Replace if necessary, see the following method description "Replacing the air distribution control knob shaft".

c that there is no play with regards to the telescoping air distribution control shaft in relation to the knob and that it is properly pressed into the heating and ventilation unit. Replace if necessary, see WIS - 9-3 - Body - MCC - Adjustment/Replacement - Control shaft.

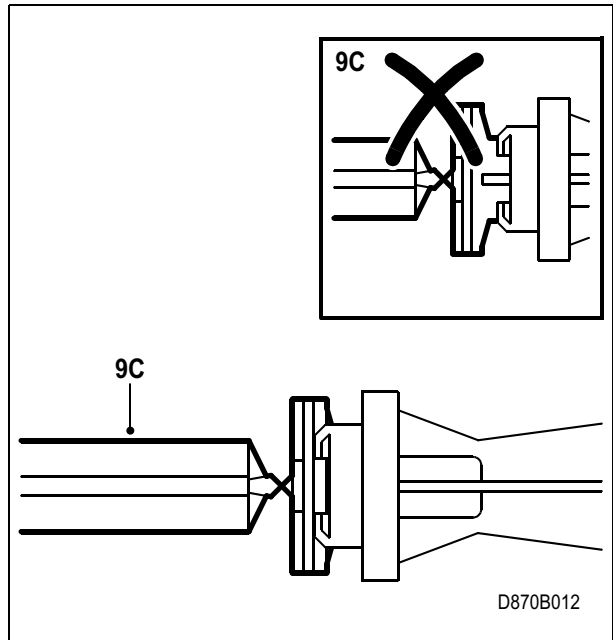
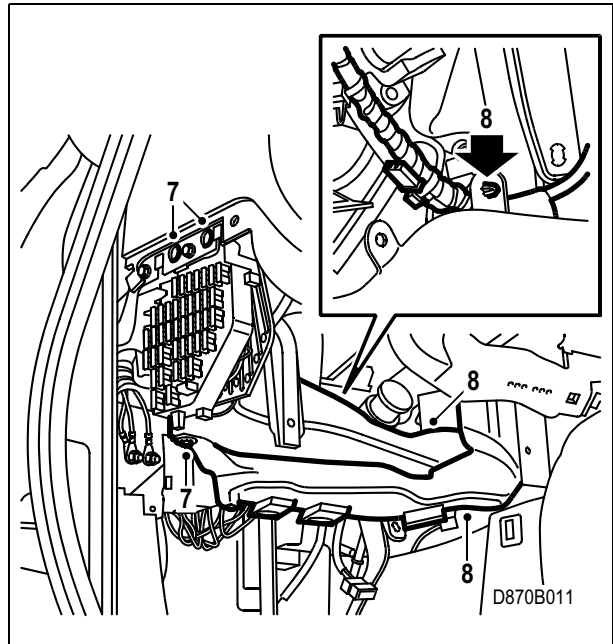

10 Remove the screw on the right-hand side.

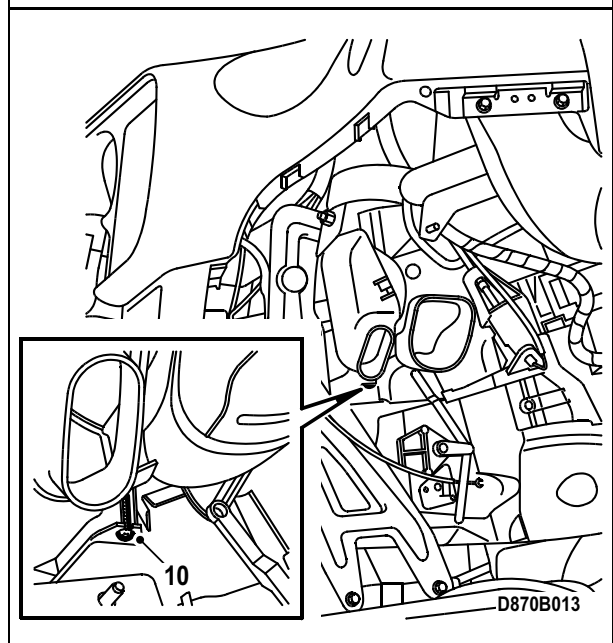

11 Remove the screw on the left-hand side.

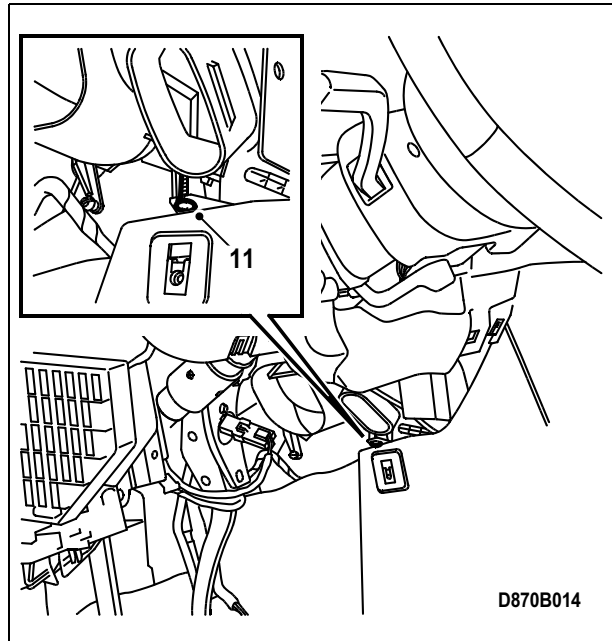

12 In those cases where the car has been previously modified with screws as shown in the illustration, remove the screws and seal the holes with sealing compound 92 88 127 on both sides.

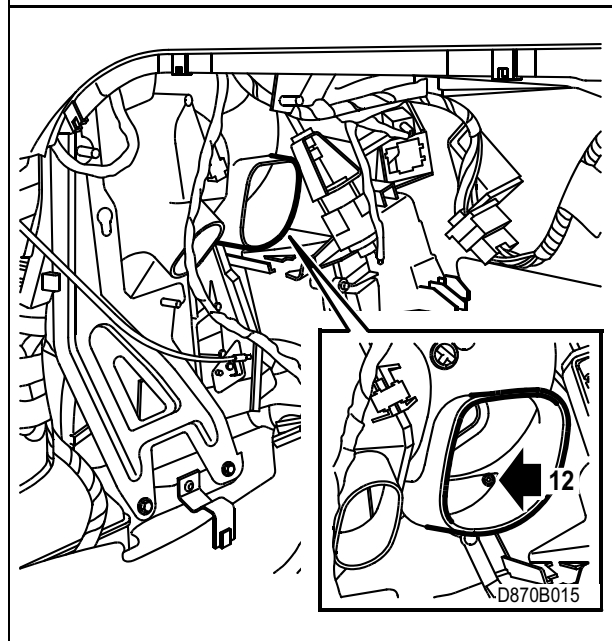

13 Fit the new screw 79 76 897 on the car's left-hand side.

Important

The screw may be inserted and tightened to a maximum of 10 mm so as not to damage the threads created in the heating and ventilation unit.

